

SEATTLE

THE AUTOMATIC L BAR SEALER
SEATTLE SERIES IS A GREAT MACHINE
FOR HIGH-SPEED PACKAGING
APPLICATIONS.

The Automatic L Bar Sealer SEATTLE series is a great machine for high-speed packaging applications. An extremely versatile machine capable of running a wide variety of industrial or consumer products. Excellent price/quality ratios are the main features characterizing the automatic L Bar sealers of the SEATTLE series.



Model SEATTLE	SEATTLE-600	SEATTLE-800
Sealing Bars Dimension (Inch-MM)	24 x 18 7/8 610 x 480	33 7/8 x 26 3/8 860 x 670
Max. Pack Height (Inch-MM)	7 7/8 200	10 250
Packing Capacity (pcs/h)	Up to 3000	Up to 2100
Conveyor Speed (Ft/Min - Mt/Min)	98 30	98 30
Center seal function	Yes	Yes
Max. Film Width (Inch - MM)	20 600	24 850
Usable Films> (Poliolefins, PVC, PP)	Up to 120 Ga (30μ)	Up to 120 Ga (30μ)
Power Supply	1 Ph. 220V 50/60Hz	1 Ph. 220V 50/60Hz
Power Max.	3.2 Kw	3.6 Kw
Compressed Air	6 bar, 90 L/min	6 bar, 90 L/min
Machine Dimension (LxWxH) (Inch-MM)	80 x 61 x 64	97 x 67 x 65
	2040 x 1550 x 1650	2473 x 1713 x 1670
Weight (net-gross) (Lb-Kg)	1345 / 1720	1654 / 2095
	610 / 780	750 / 950

LA-6000CS / LA-8000CS4 (mm)

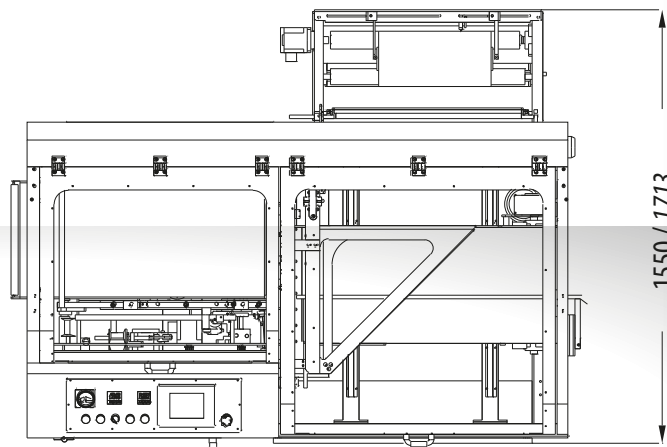
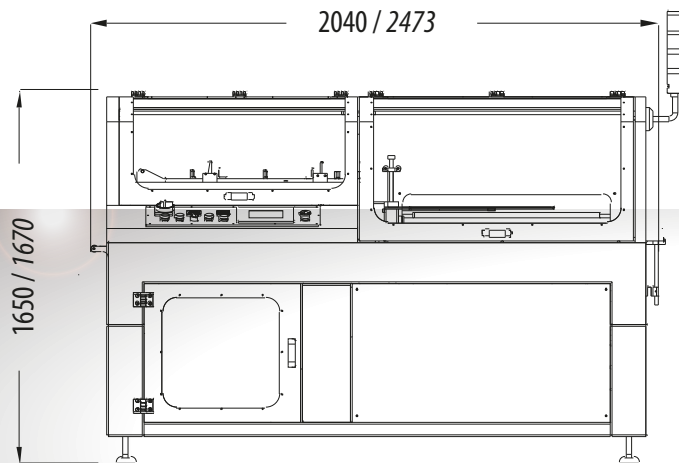

Options:

- Stainless Steel Case AISI #304.
- Complete AISI #304 Stainless Steel Construction for Cold and Wet Zone (Not Wash-down)
- Printing Film Photo sensor
- 1 .5M infeed conveyor
- Automatic Product Pusher
- 3 meters length lugs pushing conveyor

SEATTLE Series

Standard Features

- Panasonic PLC control system and 7" colorful touch "Kinco" screen operation interface.
- 20 program memory with multiple languages.
- Using HMI screen adjustment of sealing time adjustment, possibility of packaging individual packs or groups of products, conveyor belt speed, alarms, Pieces Counter, Set by Batch, etc.
- Mitsubishi frequency inverter for conveyors.
- Inverters for each motor.
- L sealing bar with PTFE-coated.
- Sealing bar controlled Pneumatic Cylinder (Standard) or SCHNEIDER SERVO MOTOR (Optional)
- Horizontal and Vertical sensors for packing of different products..
- 2 PID temperature controllers for Transversal sealing and Side Sealing.
- Motorized center seal system.
- Kissing belt function for small products or irregular shape products, can be on or off on touch screen.
- Self-contained scrap removal system with built-in alarm.
- Quick change over between productions and sizes.
- Emergency button
- Safety cover door comply with CE standard, Open door will stop the machine.
- Painted Steel.
- Machine includes Heavy Duty Castors for easy movement.
- Electric Cabinet compliance with CE regulations



769 Shotgun Rd., Sunrise, FL, 33326 - USA

Ph: +1 754.779.7800

sales@bairespackusa.com

www.bairespackusa.com